

1A Lithium Battery Charger IC CN3152

General Description:

The CN3152 is a complete constant-current /constant voltage linear charger for single cell Li-ion and Li Polymer rechargeable batteries. The device contains an on-chip power MOSFET and eliminates the need for the external sense resistor and blocking diode. Its low external component count makes CN3152 ideally suited for portable applications.

Thermal feedback regulates the charge current to limit the die temperature during high power operation or high ambient temperature. The regulation voltage is fixed at 4.2V with 1% accuracy. The charge current can be set externally with a single resistor. When the input supply is removed, the CN3152 automatically enters a low power sleep mode , dropping the battery drain current to less than 3uA. Other features include undervoltage lockout, automatic recharge, chip enable function, battery temperature monitoring and charge status indications.

The CN3152 is available in a thermally enhanced 8-pin SOP package(eSOP8).

Applications:

- Cellular Telephones
- Digital Still Cameras
- Power Bank
- Portable Devices
- Standalone Chargers

Features:

- Complete Charge Management for Single Cell Lithium Battery
- On-chip Power MOSFET
- No external Blocking Diode or Current Sense Resistors Required
- Preset 4.2V Regulation Voltage with 1% Accuracy
- Precharge Conditioning for Reviving Deeply Discharged Cells and Minimizing Heat Dissipation During Initial Stage of Charge
- Charge Current Up to 1A
- Constant-Current/Constant-Voltage Operation with Thermal Regulation to Maximize Charge Rate Without Risk of Overheating
- Automatic Low-Power Sleep Mode When Input Supply Voltage is Removed
- Status Indications for LEDs or uP Interface
- C/10 Charge Termination
- Automatic Recharge
- Battery Temperature Monitoring
- Chip Enable Input
- Available in eSOP8 Package
- Pb-free, rohs-compliant and Halogen-free

Pin Assignment

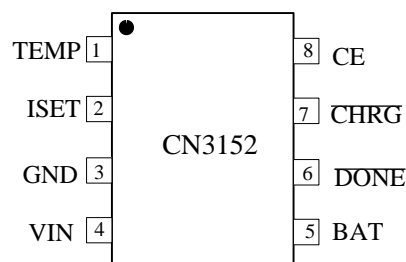

CONSONANCE

Typical Application Circuit

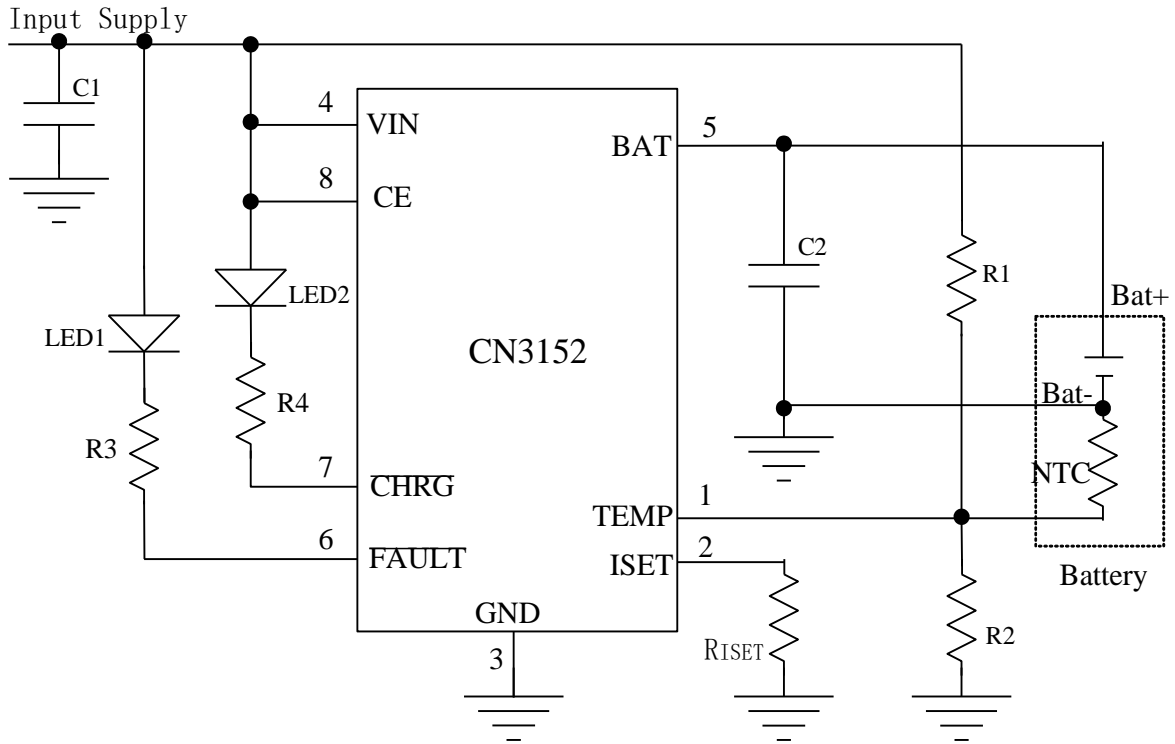

Figure 1 Typical Application Circuit

Ordering Information

Part No.	Package	Top Marking	Shipment
CN3152	eSOP8	CN3152	Tape and Reel, 4000pcs/Reel

CONSONANCE

Block Diagram

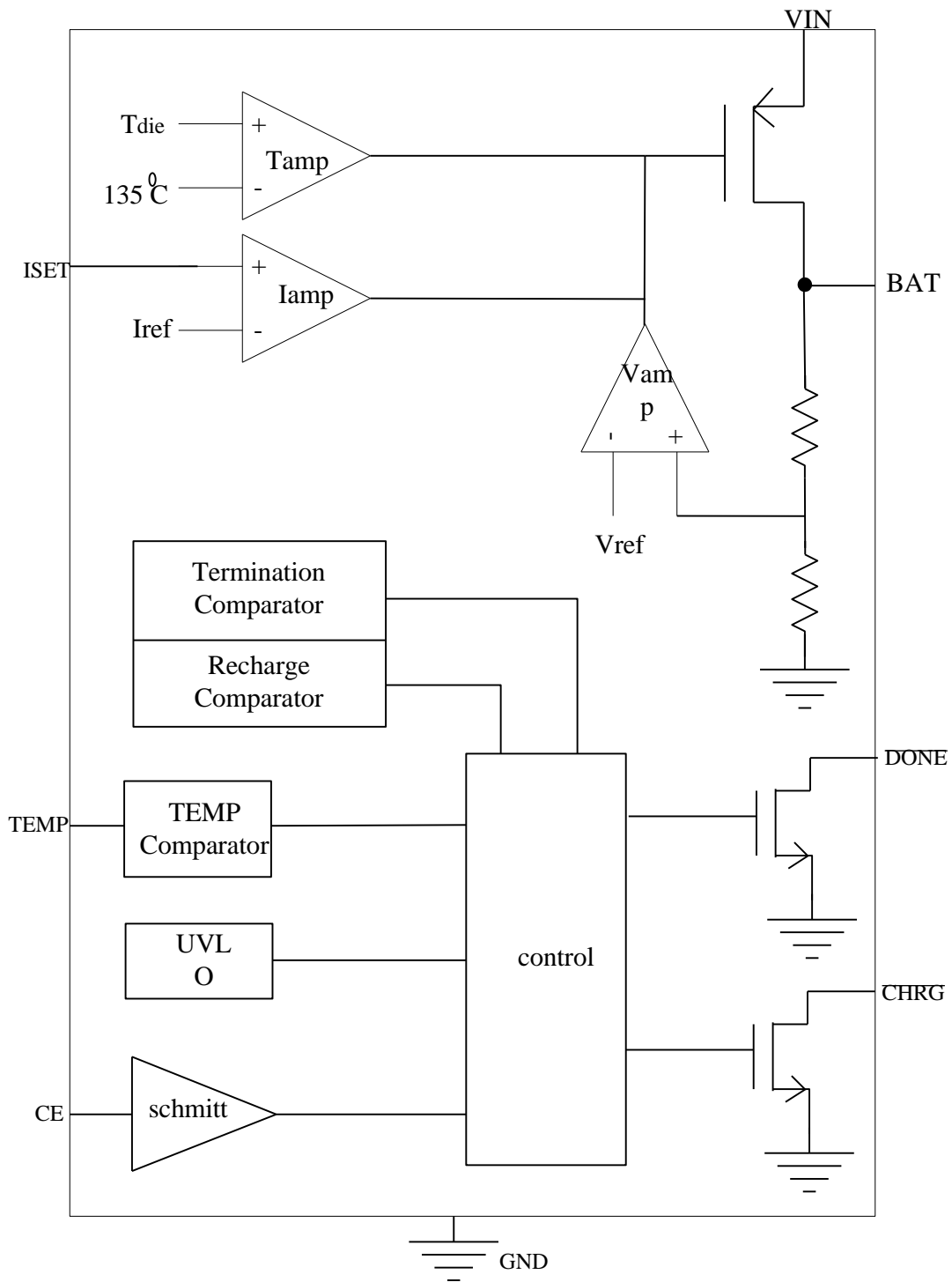

Figure 2 Block Diagram

CONSONANCE

Pin Description

Pin No.	Name	Function Description
1	TEMP	Temperature Sense Input. Connecting TEMP pin to NTC thermistor's output in Lithium ion battery pack. If TEMP pin's voltage is below 45% or above 80% of supply voltage VIN, this means that battery's temperature is too high or too low, charging is suspended. If TEMP's voltage level is between 45% and 80% of supply voltage, charging will resume. The temperature sense function can be disabled by grounding the TEMP pin.
2	ISET	Constant Charge Current Setting and Charge Current Monitor Pin. The charge current is set by connecting a resistor R _{ISET} from this pin to GND. In precharge mode, the ISET pin's voltage is regulated to 0.12V. In constant charge current mode, the ISET pin's voltage is regulated to 1.205V. In all modes during charging, the voltage on ISET pin can be used to measure the charge current as follows: $I_{CH} = (V_{ISET} / R_{ISET}) \times 1011$
3	GND	Ground Terminal.
4	VIN	Positive Input Supply Voltage. VIN is the power supply to the internal circuit. When VIN drops to within 10mv of the BAT pin voltage, CN3152 enters low power sleep mode, dropping BAT pin's current to less than 3uA.
5	BAT	Battery Connection Pin. Connect the positive terminal of the battery to BAT pin. BAT pin draws less than 3uA current in chip disable mode or in sleep mode. BAT pin provides charge current to the battery and provides regulation voltage of 4.2V.
6	\overline{DONE}	Charge termination Status Output. Open drain output. In charge termination status, \overline{DONE} is pulled low by an internal switch; Otherwise \overline{DONE} pin is in high impedance state.
7	\overline{CHRG}	Charge Status Output. Open drain output. When the battery is being charged, the \overline{CHRG} pin is pulled low by an internal switch, otherwise \overline{CHRG} pin is in high impedance state.
8	CE	Chip Enable Input. A high input will put the device in the normal operating mode. Pulling the CE pin to low level will put the CN3152 into disable mode. The CE pin can be driven by TTL or CMOS logic level.
9	Exposed PAD	Exposed Thermal PAD. Always solder the exposed PAD to the PCB and connected to system ground.

Absolute Maximum Ratings

All Terminal Voltage..... -0.3V to 6.5V
 BAT Short-Circuit Duration..... Continuous
 ESD Rating(HBM)..... 2KV
 Thermal Resistance (eSOP8)..... TBD

Maximum Junction Temperature..... 150°C
 Operating Temperature..... -40°C to 85°C
 Storage Temperature..... -65°C to 150°C
 Lead Temperature(Soldering, 10s)..... 300°C

Stresses beyond those listed under 'Absolute Maximum Ratings' may cause permanent damage to the device. These are stress ratings only and functional operation of the device at these or any other conditions above those indicated in the operational sections of the specifications is not implied. Exposure to Absolute Maximum Rating Conditions for extended periods may affect device reliability.

CONSONANCE

Electrical Characteristics

(VIN=5V, TA=−40°C to 85°C, Typical Values are measured at TA=25°C, unless otherwise noted)

Parameters	Symbol	Test Conditions	Min	Typ	Max	Unit
Input Supply Voltage	VIN		3.8		6	V
Operating Current	IVIN	CE=VIN, No load at BAT pin	300	450	600	uA
		Chip disable mode, CE=GND		4		
Undervoltage Lockout	Vuvlo	VIN rising		3.2	3.8	V
Regulation Voltage	VREG		4.158	4.2	4.242	V
BAT pin Current	IBAT	RISET=1.218K, constant current mode	850	1000	1150	mA
		RISET=1.218K, VBAT=2.3V termination mode, VBAT=VREG	75	100	125	
		CE=GND, disable mode			3	uA
		VIN=0V, sleep mode			3	
Precharge Threshold						
Precharge Threshold	VPRE	Voltage at BAT pin rising	2.83	2.93	3.03	V
Precharge Threshold Hysteresis	HPRE			0.24		V
Charge Termination Threshold						
Charge Termination Threshold	Vterm	Measure voltage at ISET pin	0.096	0.12	0.144	V
Recharge Threshold						
Recharge Threshold	VRECH			VREG−0.15		V
Sleep Mode						
Sleep Mode Threshold	VSLP	VIN from high to low, measures the voltage (VIN−VBAT)		10		mv
Sleep mode Release Threshold	VSLPR	VIN from low to high, measures the voltage (VIN−VBAT)		60		mv
ISET Pin						
ISET Pin Voltage	VISET	Precharge mode		0.12		V
		Constant current mode		1.205		
TEMP PIN						
High Input Threshold	VHIGH	The voltage at TEMP rises	77.5	80	82.5	%VIN
Low Input Threshold	VLOW	The voltage at TEMP falls	42.5	45	47.5	%VIN
TEMP input Current		TEMP to VIN or to GND			0.5	uA
CE Pin						
Logic Input Low	VCEL	CE voltage falling, Chip disabled			0.7	V
Logic Input High	VCEH	CE voltage rising, Chip enabled	2.2			V
CE Pin Current	ICEL	CE=GND, VIN=6V	−1			uA
	ICEH	CE=VIN=6V			1	

CONSONANCE

Electrical Characteristics (Continued from last page)

Parameters	Symbol	Test Conditions	Min	Typ	Max	Unit
$\overline{\text{CHRG}}$ Pin						
$\overline{\text{CHRG}}$ Pin Sink Current	I_{CHRG}	$V_{\text{CHRG}}=0.3\text{V}$, charge mode		10		mA
$\overline{\text{CHRG}}$ Leakage Current		$\text{CE}=\text{GND}$, $V_{\text{CHRG}}=6\text{V}$			1	uA
$\overline{\text{DONE}}$ Pin						
$\overline{\text{DONE}}$ Pin Sink Current	I_{DONE}	$V_{\text{DONE}}=0.3\text{V}$, termination mode		10		mA
$\overline{\text{DONE}}$ Pin Leakage Current		$\text{CE}=\text{GND}$, $V_{\text{DONE}}=6\text{V}$			1	uA

Detailed Description

The CN3152 is a linear battery charger designed primarily for charging single cell lithium-ion or lithium-polymer batteries. Featuring an internal P-channel power MOSFET, the charger uses a constant-current/constant-voltage to charge the batteries. Charge current can be set up to 1A with an external resistor. No blocking diode or sense resistor is required. The open-drain output $\overline{\text{CHRG}}$ and $\overline{\text{DONE}}$ indicates the charger's status. The internal thermal regulation circuit reduces the programmed charge current if the die temperature attempts to rise above a preset value of approximately 135°C. This feature protects the CN3152 from excessive temperature, and allows the user to push the limits of the power handling capability of a given circuit board without risk of damaging the CN3152 or the external components. Another benefit of adopting thermal regulation is that charge current can be set according to typical, not worst-case, ambient temperatures for a given application with the assurance that the charger will automatically reduce the current in worst-case conditions.

The charge cycle begins when the voltage at the VIN pin rises above the UVLO level, a current set resistor is connected from the ISET pin to ground, and the CE pin is pulled above the chip enable threshold. The $\overline{\text{CHRG}}$ pin outputs a logic low to indicate that the charge cycle is ongoing. At the beginning of the charge cycle, if the battery voltage is below 2.93V, the charger is in precharge mode to bring the cell voltage up to a safe level for charging. The charger goes into the fast charge constant-current mode once the voltage on the BAT pin rises above 2.93V. In constant current mode, the charge current is set by R_{ISET}. When the battery approaches the regulation voltage, the charge current begins to decrease as the CN3152 enters the constant-voltage mode. When the current drops to charge termination threshold, the charge cycle is terminated, $\overline{\text{DONE}}$ is pulled low by an internal switch and $\overline{\text{CHRG}}$ pin assumes a high impedance state to indicate that the charge cycle is terminated. The charge termination threshold is 10% of the current in constant current mode. To restart the charge cycle, remove the input voltage and reapply it, or momentarily force CE pin to 0V. The charge cycle can also be automatically restarted if the BAT pin voltage falls below the recharge threshold. The on-chip reference voltage, error amplifier and the resistor divider provide regulation voltage with 1% accuracy which can meet the requirement of lithium-ion and lithium polymer batteries. When the input voltage is not present, the charger goes into a sleep mode, dropping battery drain current to less than 3uA. This greatly reduces the current drain on the battery and increases the standby time. The CN3152 can be shutdown by forcing the CE pin to GND.

The charging profile is shown in the following figure:

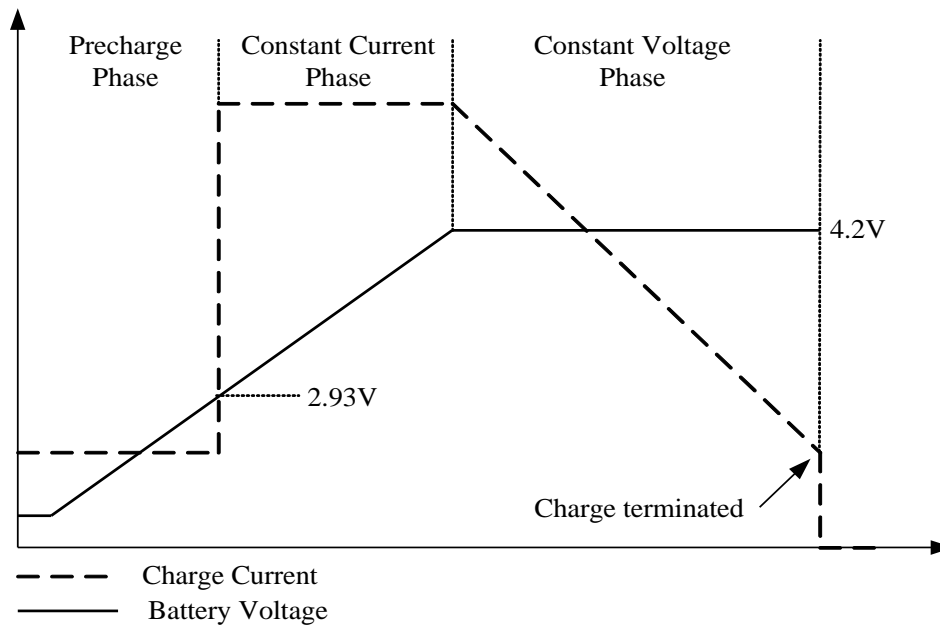

Figure 3 Charging Profile

Application Information

Undervoltage Lockout (UVLO)

An internal undervoltage lockout circuit monitors the input voltage and keeps the CN3152 in shutdown mode until VIN rises above the undervoltage lockout voltage.

Sleep mode

There is an on-chip sleep comparator. The comparator keeps the CN3152 in sleep mode if VIN falls below sleep mode threshold (VBAT+10mv). Once in sleep mode, the CN3152 will not come out of sleep mode until VIN rises 60mv above the battery voltage.

Precharge mode

At the beginning of a charge cycle, if the battery voltage is below 2.93V, the CN3152 goes into precharge mode, and the charge current is 10% of fast charge current in constant current mode.

Chip Enable/Disable

The CN3152 can be disabled by pulling the CE pin to less than 0.7V. For normal operation, pull the CE pin above 2.2V. Applying a voltage between 0.7V to 2.2V to this pin may cause larger operating current, and the CN3152 may be in uncertain state. When the chip is disabled, the internal linear regulator and the power MOSFET are turned off.

Programming Charge Current

The formula for the battery charge current in constant current mode is:

$$I_{CH} = 1218V / R_{ISET}$$

Where:

I_{CH} is the charge current in ampere

R_{ISET} is the total resistance from the ISET pin to ground in ohm

For example, if 500mA charge current is required, calculate:

$$R_{ISET} = 1218V / 0.5A = 2.436k \Omega$$

For best stability over temperature and time, 1% metal film resistors are recommended. If the CN3152 is in constant-temperature or constant voltage mode, the charge current can be monitored by measuring the ISET pin voltage, and the charge current is calculated as the following equation:

$$I_{CH} = (V_{ISET} / R_{ISET}) \times 1011$$

CONSONANCE

Battery Temperature Monitoring

To prevent the damage caused by the very high or very low temperature done to the battery pack, the CN3152 continuously senses battery pack temperature by measuring the voltage at TEMP pin determined by the voltage divider circuit and the battery's internal NTC thermistor as shown in Figure 1.

The CN3152 compares the voltage at TEMP pin (V_{TEMP}) against its internal V_{LOW} and V_{HIGH} thresholds to determine if charging is allowed. In CN3152, V_{LOW} is fixed at $(45\% \times V_{IN})$, while V_{HIGH} is fixed at $(80\% \times V_{IN})$. If $V_{TEMP} < V_{LOW}$ or $V_{TEMP} > V_{HIGH}$, it indicates that the battery temperature is too high or too low and the charge cycle is suspended. When V_{TEMP} is between V_{LOW} and V_{HIGH} , the charge cycle resumes.

The battery temperature sense function can be disabled by connecting TEMP pin to GND.

Selecting R1 and R2

The values of R1 and R2 in the application circuit can be determined according to the assumed temperature monitor range and thermistor's values. The Follows is an example:

Assume temperature monitor range is $T_L \sim T_H$ ($T_L < T_H$); the thermistor in battery has negative temperature coefficient (NTC), R_{TL} is thermistor's resistance at T_L , R_{TH} is the resistance at T_H , so $R_{TL} > R_{TH}$, then at temperature T_L , the voltage at TEMP pin is:

$$V_{TEMPL} = \frac{R_2 \parallel R_{TL}}{R_1 + R_2 \parallel R_{TL}} \times V_{IN}$$

At temperature T_H , the voltage at TEMP pin is:

$$V_{TEMPH} = \frac{R_2 \parallel R_{TH}}{R_1 + R_2 \parallel R_{TH}} \times V_{IN}$$

We know, $V_{TEMPL} = V_{HIGH} = k_2 \times V_{IN}$ ($k_2 = 0.8$)

$$V_{TEMPH} = V_{LOW} = k_1 \times V_{IN} \quad (k_1 = 0.45)$$

Then we can have:

$$R_1 = \frac{R_{TL} R_{TH} (k_2 - k_1)}{(R_{TL} - R_{TH}) k_1 k_2}$$

$$R_2 = \frac{R_{TL} R_{TH} (k_2 - k_1)}{R_{TL} (k_1 - k_1 k_2) - R_{TH} (k_2 - k_1 k_2)}$$

Likewise, for positive temperature coefficient thermistor in battery, we have $R_{TH} > R_{TL}$ and we can calculate:

$$R_1 = \frac{R_{TL} R_{TH} (k_2 - k_1)}{(R_{TH} - R_{TL}) k_1 k_2}$$

$$R_2 = \frac{R_{TL} R_{TH} (k_2 - k_1)}{R_{TH} (k_1 - k_1 k_2) - R_{TL} (k_2 - k_1 k_2)}$$

We can conclude that temperature monitor range is independent of power supply voltage V_{IN} and it only depends on R1, R2, R_{TL} and R_{TH} . The values of R_{TH} and R_{TL} can be found in related battery handbook or deduced from testing data.

In actual application, if only one terminal temperature is concerned (normally protecting overheating), there is no need to use R2 but R1. It becomes very simple to calculate R1 in this case.

Recharge

After a charge cycle has terminated, if the battery voltage drops below the recharge threshold of 4.05V, a new charge cycle will begin automatically.

CONSONANCE

Constant-Current/Constant-Voltage/Constant-Temperature

The CN3152 use a unique architecture to charge a battery in a constant-current, constant-voltage, constant temperature fashion as shown in Figure 2. Amplifiers Iamp, Vamp, and Tamp are used in three separate feedback loops to force the charger into constant-current, constant-voltage, or constant-temperature mode, respectively. In constant current mode the charge current delivered to the battery equal to $1218V/R_{ISET}$. If the power dissipation of the CN3152 results in the junction temperature approaching $135^{\circ}C$, the amplifier Tamp will begin decreasing the charge current to limit the die temperature to approximately $135^{\circ}C$. As the battery voltage rises, the CN3152 either returns to constant-current mode or it enters constant voltage mode straight from constant-temperature mode.

Open-Drain Status Outputs

The CN3152 has 2 open-drain status outputs: \overline{CHRG} and \overline{DONE} . \overline{CHRG} is pulled low when the charger is in charging mode, otherwise \overline{CHRG} becomes high impedance. \overline{DONE} is pulled low if the charger is in charge termination mode, otherwise \overline{DONE} becomes high impedance.

When the battery is not present, the CN3152 charges the output capacitor to the regulation voltage quickly, then the BAT pin's voltage decays slowly to recharge threshold because of low leakage current at BAT pin, which results in a 150mv ripple waveform at BAT pin, in the meantime, \overline{CHRG} pin outputs high-impedance state, \overline{DONE} pin outputs pulse.

The open drain status output that is not used should be tied to ground.

VIN Bypass Capacitor

Many types of capacitors can be used for input bypassing(C1 in Figure 1), Generally, a 1uF ceramic capacitor, placed in close proximity to VIN and GND pins, works well. In some applications depending on the power supply characteristics and cable length, it may be necessary to increase the capacitor's value.

If the ceramic capacitor is used as the input supply bypassing purpose, a voltage spike may be created when the input voltage is applied to the CN3152 via a cable. If the cable is a bit long, the circuit shown in Figure 4 or a TVS diode from VIN pin to GND should be considered to use to prevent the CN3152 from being damaged by the voltage spike.

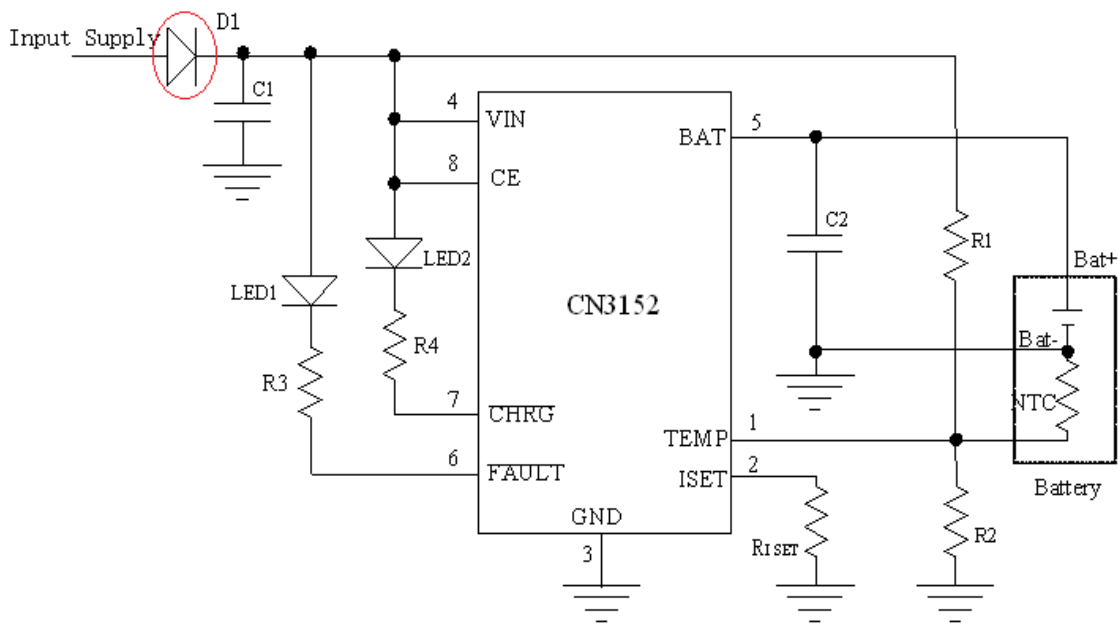

Figure 4 Adding Diode D1 to Suppress Voltage Spike

CONSONANCE

Stability

Typically a 4.7uF to 10uF capacitor(C2 in Figure 1) from BAT pin to GND is required to stabilize the feedback loop.

In constant current mode, the stability is also affected by the impedance at the ISET pin. With no additional capacitance on the ISET pin, the loop is stable with current set resistors values as high as 50K Ω . However, additional capacitance on ISET pin reduces the maximum allowed current set resistor. The pole frequency at ISET pin should be kept above 200KHz. Therefore, if ISET pin is loaded with a capacitance C, the following equation should be used to calculate the maximum resistance value for R_{ISET}:

$$R_{ISET} < 1 / (6.28 \times 2 \times 10^5 \times C)$$

Board Layout Considerations

1. R_{ISET} at ISET pin should be as close to CN3152 as possible, also the parasitic capacitance at ISET pin should be kept as small as possible.
2. The capacitance at VIN pin and BAT pin should be as close to CN3152 as possible.
3. During charging, CN3152's temperature may be high, the NTC thermistor should be placed far enough to CN3152 so that the thermistor can reflect the battery's temperature correctly.
4. It is very important to use a good thermal PC board layout to maximize charging current. The thermal path for the heat generated by the IC is from the die to the copper lead frame through the package lead(especially the ground lead) to the PC board copper, the PC board copper is the heat sink. The footprint copper pads should be as wide as possible and expand out to larger copper areas to spread and dissipate the heat to the surrounding ambient. Feedthrough vias to inner or backside copper layers are also useful in improving the overall thermal performance of the charger. Other heat sources on the board, not related to the charger, must also be considered when designing a PC board layout because they will affect overall temperature rise and the maximum charge current.

The ability to deliver maximum charge current under all conditions require that the exposed metal pad on the back side of the CN3152 package be soldered to the PC board ground. Failure to make the thermal contact between the exposed pad on the backside of the package and the copper board will result in larger thermal resistance.

CONSONANCE

Package Information(eSOP8)

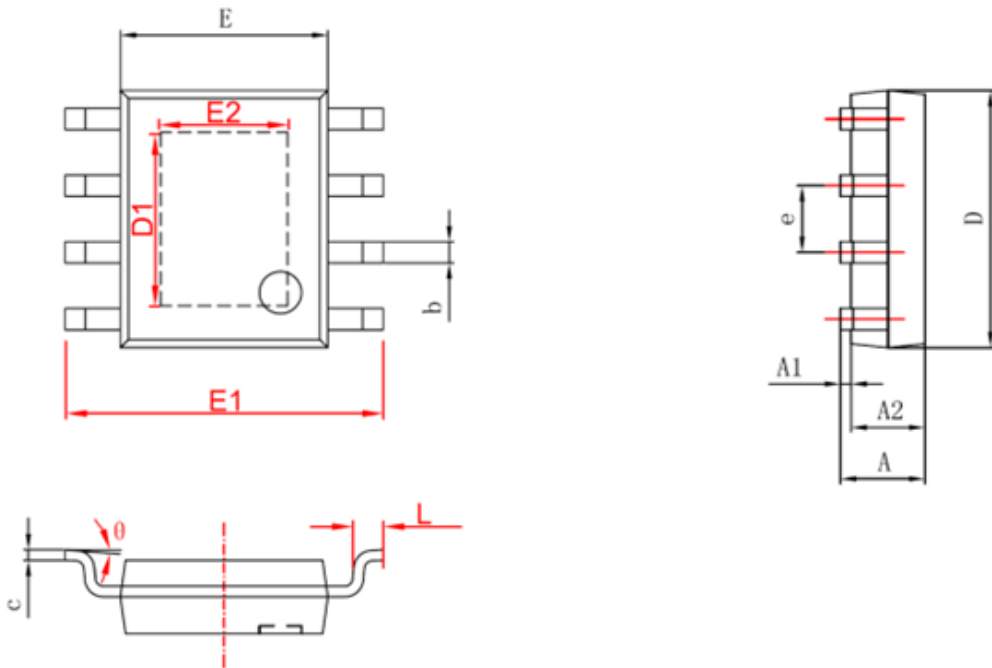

Symbol	Dimensions In Millimeters		Dimensions In Inches	
	Min	Max	Min	Max
A	1.350	1.750	0.053	0.069
A1	0.050	0.150	0.004	0.010
A2	1.350	1.550	0.053	0.061
b	0.330	0.510	0.013	0.020
c	0.170	0.250	0.006	0.010
D	4.700	5.100	0.185	0.200
D1	3.202	3.402	0.126	0.134
E	3.800	4.000	0.150	0.157
E1	5.800	6.200	0.228	0.244
E2	2.313	2.513	0.091	0.099
e	1.270 (BSC)		0.050 (BSC)	
L	0.400	1.270	0.016	0.050
θ	0°	8°	0°	8°

Important Notice

Consonance Electronics reserves the right to make corrections, modifications, enhancements, improvements and other changes to its products and specifications at any time without notice.

Consonance Electronics assumes no liability for applications assistance or technique support or the use of any circuitry described in the specification during customer product designing and developing. Customers are solely responsible for their products and applications using Consonance Electronics products. Customer should provide adequate design, test and operating safeguard based on its products' operating environment and conditions.