

PFM Step-up Battery Charger Controller IC CN3300

General Description:

The CN3300 is a step up battery charger controller IC which operates from an input voltage of 4V to 28V. The CN3300 includes on-chip reference voltage, +5V voltage regulator, inductor current sensing, battery voltage monitoring and N-channel MOSSFET driving blocks, etc, which makes the CN3300 easy to be used with few external components.

The CN3300 enter charging mode on power up, the external N-channel MOSFET is turned on, when the inductor current rises to the upper limit, the N-channel MOSFET is turned off, then inductor current begins to fall, the energy stored in inductor is transferred to the battery. When inductor current falls to the lower limit, the external N-channel MOSFET is turned on again, and a new cycle starts. Battery voltage is feedback to FB pin via the external resistor divider, when the voltage at FB pin reaches 1.205V(Typical), the charging is terminated, the external N-channel MOSFET remains off until the voltage at FB pin decreases to recharge threshold, The maximum switching frequency of CN3300 is 1MHz.

CN3300 adopts 6-pin SOT23 package.

Applications:

- Lithium ion battery charger
- LiFePO4 battery charger
- Lead-Acid battery charger
- Standalone battery charger

Features:

- Input Voltage Range: 4V to 28V
- Inductor Current Sensing
- Battery Voltage Monitoring
- Up to 1MHz Switching Frequency
- Automatic Recharge
- Up to 25W Output Power
- On-Chip Voltage Regulator: 5V, 5mA
- Operating Temperature Range: -40°C to 85°C
- 6-Pin SOT23 Package
- Lead-free, rohs-Compliant, Halogen-free

Pin Assignment:

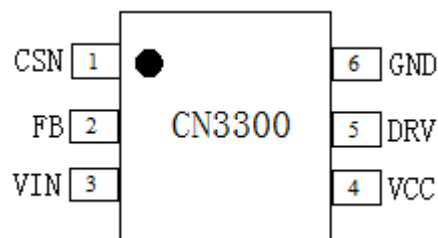

CONSONANCE

Typical Application Circuit:

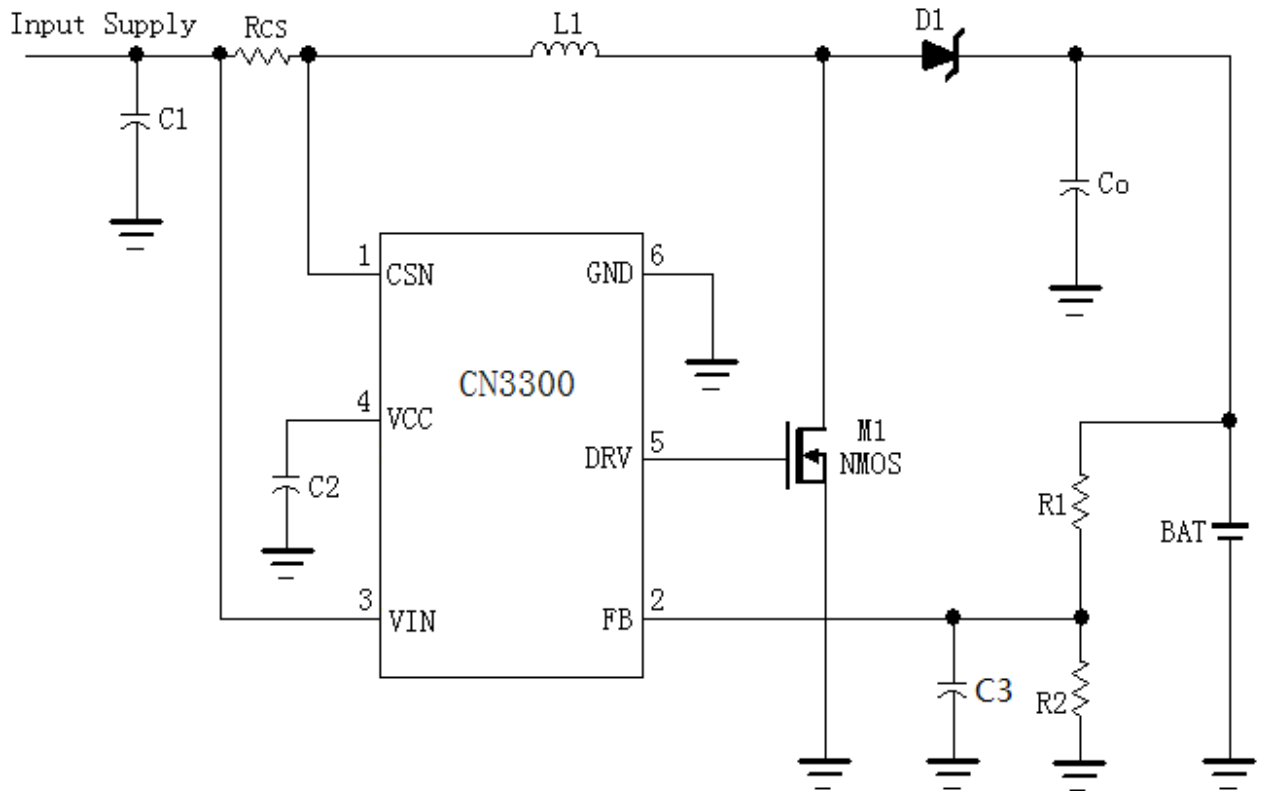

Figure 1 Typical Application Circuit

Block Diagram:

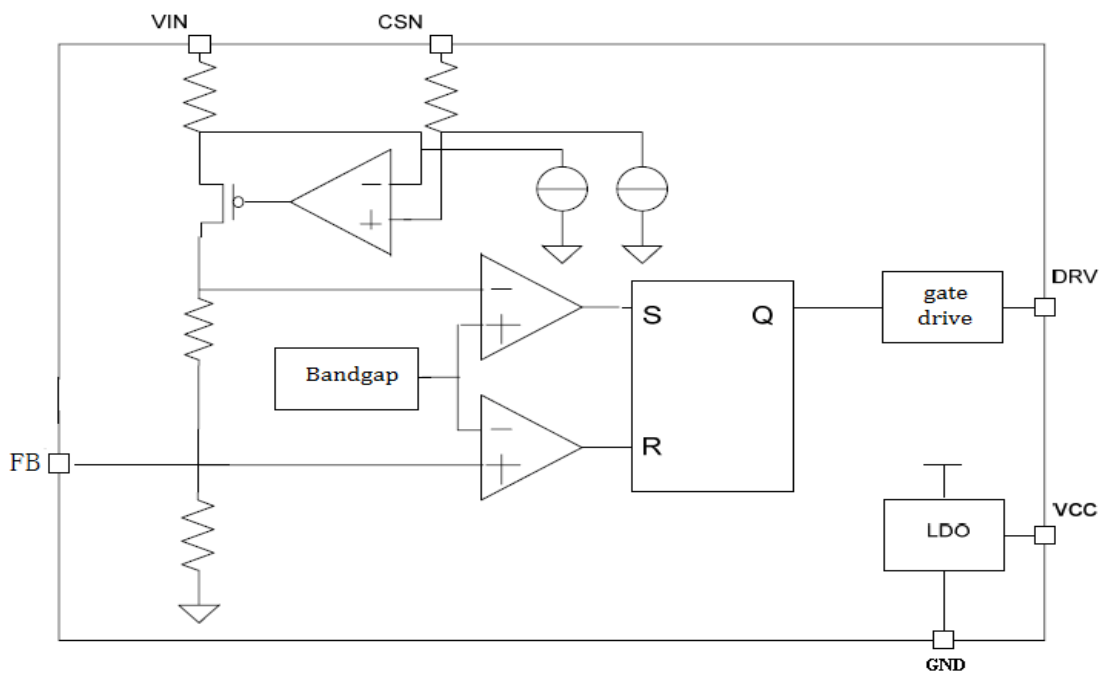

Figure 2 Block Diagram

CONSONANCE

Ordering Information:

Part No.	Package Type	Pack	Operating Temperature Range
CN3300	SOT23-6	Tape and Reel, 3000/Reel	-40°C to 85°C

Pin Description

No.	Name	Description
1	CSN	Negative Input of Inductor Current Sense. A current sense resistor R_{CS} between VIN and CSN is needed to sense the inductor current. In normal operation, (VIN-CSN) is between 120mV and 150mV(Typical).
2	FB	Battery Voltage Feedback Input. Generally, FB pin should be connected to an external resistor divider to monitor the battery voltage. When the voltage at FB pin rises to 1.205V (Typical), the CN3300 enters termination mode, and enters charge mode again if the voltage at FB pin falls below 1.155V(Typical).
3	VIN	The Positive Terminal of Input Supply. In addition to powering the internal circuits, VIN pin also serves as the positive terminal of inductor current sense.
4	VCC	+5V Regulator Output. Connect a 4.7uF or 10uF capacitor from VCC to GND, the maximum output current is 5mA.
5	DRV	Gate Drive Output for External MOSFET. Connect to the gate of an external N-channel MOSFET.
6	GND	Ground(GND).

ABSOLUTE MAXIMUM RATINGS

VIN ,CSN to GND.....	-0.3V to 30V	Maximum Junction Temperature.....	150°C
VCC to GND.....	-0.3V to 6.5V	Operating Temperature Range.....	-40°C to 85°C
CSN to VIN.....	-0.3V to 0.3V	Storage Temperature Range.....	-65°C to 150°C
FB, DRV.....	-0.3V to VCC	Lead Temperature(Soldering,10S).....	260°C

Stresses beyond those listed under “Absolute Maximum Ratings” may cause permanent damage to the device. These are stress ratings only, and functional operation of the device at these or any other conditions beyond those indicated in the operational sections of the specifications is not implied. Exposure to absolute maximum rating conditions for extended periods may affect device reliability.

CONSONANCE

ELECTRICAL CHARACTERICS

(VIN = 12V, TA = -40°C to +85°C, Typical values are at TA = +25°C, unless otherwise noted)

Parameters	Symbol	Test Conditions	Min	Typ	Max	Unit
Input Voltage Range	VIN		4		28	V
Switching Frequency	f _{SW}				1	MHz
Operating Current	I _{VIN}	V _{FB} = 1.25V, No Switching	395	515	635	uA
Inductor Current Sense Comparator						
Sense Threshold High	V _{CSHI}	(VIN - V _{CSN}) rises from 0V, until V _{DRV} < 0.5V	120	150	180	mV
Sense Threshold Low	V _{CSLO}	(VIN - V _{CSN}) falls from 0.2V until V _{DRV} > (VCC - 0.5V)	96	120	144	mV
Propagation Delay to Output High	t _{DPDH}	(VIN - V _{CSN}) from 0.2V to 0.07V		82		ns
Propagation Delay to Output Low	t _{DPDL}	(VIN - V _{CSN}) from 0V to 0.2V		82		ns
CSN Input Current	I _{CSN}				1	uA
FB Pin						
FB Charge Termination Threshold	V _{term}	FB voltage rises	1.19	1.205	1.22	V
FB Recharge Threshold	V _{rech}	FB voltage falls	1.13	1.155	1.18	V
FB Current	I _{FB}		-100		+100	nA
DRV Pin						
Source Current		V _{CSN} = VIN, V _{DRV} = 0.5 × VCC		0.5		A
Sink Current		V _{CSN} = VIN - 0.22V, V _{DRV} = 0.5 × VCC		1		A
Output Voltage High	V _{OH}	I _{DRV} = 5mA	VCC - 0.5			V
Output Voltage Low	V _{OL}	I _{DRV} = -10mA			0.5	V
VCC Pin						
Regulation Voltage	VCC	I _{VCC} = 0.1mA to 5mA, VIN = 5.5V to 30V	4.5		5.5	V
Load Regulation		I _{VCC} = 0.1mA to 5mA,		5		ohm
Line Regulation		VIN = 6V to 28V, I _{VCC} = 3mA		6		mV
PSRR	PSRR	I _{VCC} = 3mA, f _{IN} = 10kHz		-35		dB
Start Time	t _{START}	VCC = 0 to 4.5V		350		us

Detailed Description

The CN3300 is a step up battery charger controller IC which operates from an input voltage of 4V to 28V. The CN3300 includes an on-chip reference voltage, +5V voltage regulator, inductor current sensing, battery voltage monitoring and N-channel MOSFET driving blocks, etc, which makes the CN3300 easy to be used with few external components.

The CN3300 enters charge mode on power up, the external N-channel MOSFET is turned on, inductor current rises. When the inductor current rises to the upper limit, the N-channel MOSFET is turned off, and inductor current begins to fall, the energy stored in inductor is transferred to the battery. When inductor current falls to the

CONSONANCE

lower limit, the external N-channel MOSFET is turned on again, and a new cycle starts. Battery voltage is feedback to FB pin via the external resistor divider, when the voltage at FB pin rises to 1.205V(Typical), the charging is terminated, the external N-channel MOSFET remains off until the voltage at FB pin decreases to recharge threshold, which will make CN3300 enter charge status again. The maximum switching frequency of CN3300 can be up to 1MHz.

Application Information

About Input Voltage Range

CN3300 operates from a 4V to 28V input voltage. When the input voltage is between 4V to 5.5V, the voltage at VCC pin may be less than 5V, though CN3300 can function correctly.

5V Voltage Regulator

VCC is the output of a 5V regulator capable of sourcing 5mA. Bypass VCC to GND with a 4.7μF to 10μF capacitor.

Inductor Current (Input Current)

In the application circuit shown in Figure 1, CN3300 sets the inductor current through a current sense resistor R_{CS} connected between VIN and CSN pin.

When the external N-channel MOSFET is turned on, inductor current rises, when inductor current rises to:

$$I_{Lhigh} = 0.15V / R_{CS}$$

The external N-channel MOSFET is turned off, inductor current falls, and the energy is transferred to the battery and the output capacitor. When inductor current falls to:

$$I_{Llow} = 0.12V / R_{CS}$$

The external N-channel MOSFET is turned on again, and a new cycle begins.

So, average inductor current is: $I_L = 0.135V / R_{CS}$

In the above 3 equations, I_{Lhigh} is upper limit of inductor current in ampere(A)

I_{Llow} is lower limit of inductor current in ampere(A)

R_{CS} is current sense resistor in ohm(Ω)

Calculate Switching Frequency and Duty Cycle

In the application circuit shown in Figure 1, the on-time of external N-channel MOSFET is:

$$t_{on} = \frac{0.03 \times L}{V_{IN} \times R_{CS}}$$

The off-time of external N-channel MOSFET is:

$$t_{off} = \frac{0.03 \times L}{(V_{BAT} + V_D - V_{IN}) \times R_{CS}}$$

Switching frequency is:

$$f_{sw} = \frac{1}{t_{on} + t_{off}} = \frac{1}{\frac{0.03 \times L}{V_{IN} \times R_{CS}} + \frac{0.03 \times L}{(V_{BAT} + V_D - V_{IN}) \times R_{CS}}}$$

Duty cycle is:

$$D = \frac{t_{on}}{t_{on} + t_{off}} = \frac{V_{BAT} + V_D - V_{IN}}{V_{BAT} + V_D}$$

In the above 4 equations, L is inductor value in Henry(H)

CONSONANCE

- V_{IN} is input voltage in Volt(V)
- V_{BAT} is battery voltage in Volt(V)
- V_D is the forward voltage of diode D1 in Volt(V)
- R_{CS} is inductor current sense resistor in ohm(Ω)

Estimate Charge Current

CN3300 controls the charge current by controlling inductor current(Input current), so the charge current will vary with the input voltage and battery voltage.

Generally, the charge current can be estimated by the following equation:

$$I_{CH} = \frac{V_{IN} \times I_L \times \eta}{V_{BAT}}$$

- Where,
- I_{CH} is the charge current in Ampere (A)
 - V_{IN} is input supply in Volt(V)
 - I_L is average inductor current, which is determined by 0.135 / R_{CS} in Ampere(A)
 - η is converter's efficiency, which is around 85%
 - V_{BAT} is battery voltage in Volt(V)

Charge Termination Voltage at Battery Terminal

In the application circuit shown in Figure 1, battery voltage is feedback to FB pin via the resistor divider formed by R1 and R2, CN3300 decides the charge status based on FB's voltage. When FB voltage rises to 1.205V (Typical), CN3300 enters termination mode.

The voltage at battery terminal when the charging is terminated:

$$V_{BAT} = 1.205 \times (1 + R1 / R2)$$

Since R1 and R2 will draw some current from the battery, R1+R2 should be chosen first according to the current consumption affordable, then calculate R1 and R2 based on the above equation.

When designing the charge termination voltage at the battery terminal, the battery's internal resistance and the parasitic resistance from the PCB to the battery's terminals should be taken into consideration. As illustrated in Figure 3, R_B is the battery's internal resistance, R_W is the parasitic resistance including the metal wire's resistance, plug contact resistance, etc.

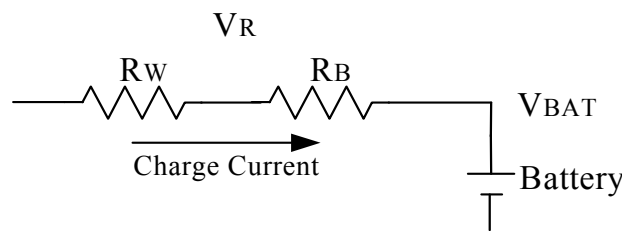

Figure 3 Battery's Internal Resistance and Parasitic Resistance

In charge mode, charge current flows through the resistor R_B and R_W, a voltage drop V_R is generated. Assume that the true battery voltage is V_{BAT}, but the detected voltage by CN3300 is V_{BAT} + V_R, which does not accurately reflect the battery voltage. Therefore, when designing the charge termination voltage, the voltage drop V_R should be considered to make sure that the battery is fully charged.

The simple way to compensate V_R is to make:

$$V_{final} = V_{BAT} + V_R$$

Where, V_{final} is the designed charge termination voltage at battery terminal

V_{BAT} is battery voltage when fully charged

CONSONANCE

V_R is the voltage drop across the battery's internal resistance and parasitic resistance

Charge Termination

When the voltage at FB pin rises to 1.205V (Typical), the charging is terminated, the external N-channel MOSFET is turned off, CN3300 is in charge termination status, in which there is no charge current flowing to the battery.

Recharge

In charge termination mode, if FB voltage falls to 1.155V(Typical), CN3300 will enter charge mode again.

MOSFET Selection

The CN3300's gate driver is capable of sourcing 0.5A and sinking 1A of current. MOSFET selection is based on the maximum battery voltage, inductor current and operating switching frequency. Choose an N-channel MOSFET that has a higher breakdown voltage than the maximum battery voltage, low $R_{ds(ON)}$, and low total gate charge(Q_g) for better efficiency. MOSFET threshold voltage must be adequate if operated at the low end of the input-voltage operating range.

Freewheeling Diode Selection

The forward voltage of the freewheeling diode should be as low as possible for better efficiency. A Schottky diode is a good choice as long as the breakdown voltage is high enough to withstand the maximum battery voltage. The forward current rating of the diode must be at least equal to the maximum charge current.

Input Bypass Capacitor

In most applications, a bypass capacitor at V_{IN} is needed. An at least 1uF ceramic capacitor, placed in close proximity to V_{IN} and GND pins, works well. In some applications depending on the power supply characteristics and cable length, it may be necessary to increase the capacitor's value. The capacitor's breakdown voltage should be higher than the maximum input voltage.

Output Capacitor

An at least 10uF capacitor is needed between output and ground(GND).

About Capacitor C3

In the typical application circuit shown in Figure 1, capacitor C3 is used to filter out the high frequency noise so that the charger can be terminated correctly. Capacitor C3 is estimated by the below equation:

$$C3 = \frac{5\Pi}{f_{sw} \times \frac{R1R2}{R1+R2}}$$

Where,

- Π is equal to 3.14
- f_{sw} is the converter's switching frequency
- R1 and R2 are the feedback resistors shown in Figure 1

C3's capacitance can not be much larger than the value calculated from the above equation, otherwise the output voltage may go so high that damage may be caused when the battery is absent.

Add Charging Status Indication

The following circuit can be used to add charging status indication and termination status indication.

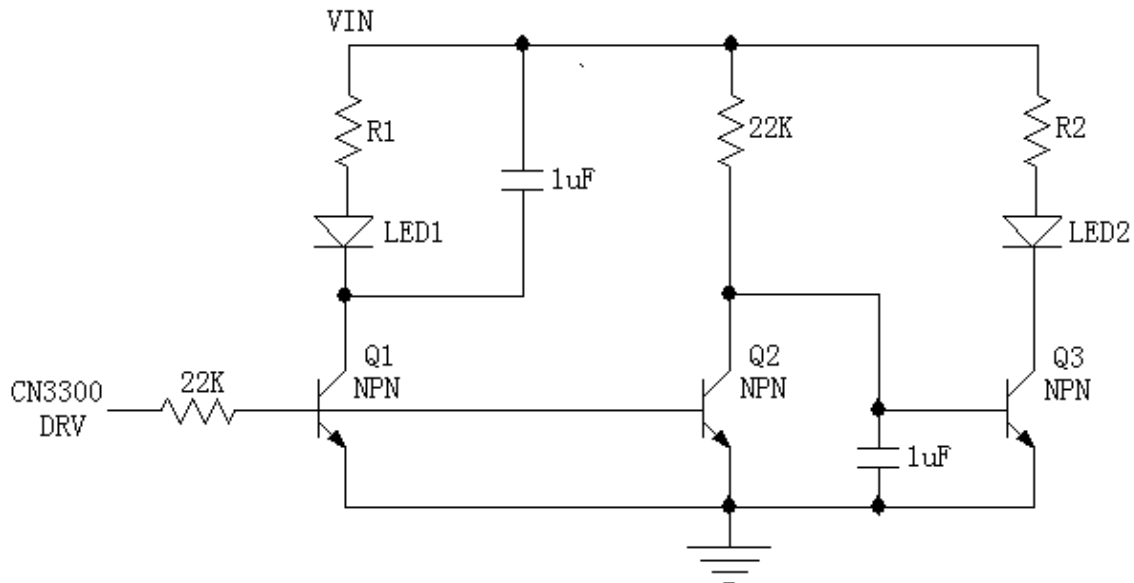

Figure 4 Charging Status Indication

Where, CN3300 DRV is CN3300's DRV pin, VIN is the charger's input voltage. LED1 is for charging status indication, LED2 is for termination indication. R1 and R2 are the LED current limit resistors.

Design Procedure

The following procedure should be followed to design CN3300's application circuit:

- (1) Decide charge current based on the battery capacity and charge time
- (2) Estimate average inductor current based on input voltage, battery voltage and charge current
- (3) Decide R_{CS} based on average inductor current
- (4) Determine the inductor value based on the switching frequency
- (5) Design resistor divider formed by R1 and R2 for battery voltage feedback
- (6) Calculate capacitance of C3

PCB Considerations

Careful PCB layout is critical to achieve low switching losses and stable operation.

- Use a multilayer board whenever possible for better noise immunity.
- The negative terminals of input bypass capacitor and output capacitor should be as close as possible to the source of N-channel MOSFET
- The analog ground should be separated with power ground plane.
- To ensure low EMI, the copper plane for diode, N-channel MOSFET, inductor, input capacitor and output capacitor should be as small as possible,
- The current sense resistor R_{CS} should be placed closely to input bypassing capacitors.

CONSONANCE

Package Information

SOT-23-6L(12R) PACKAGE OUTLINE DIMENSIONS

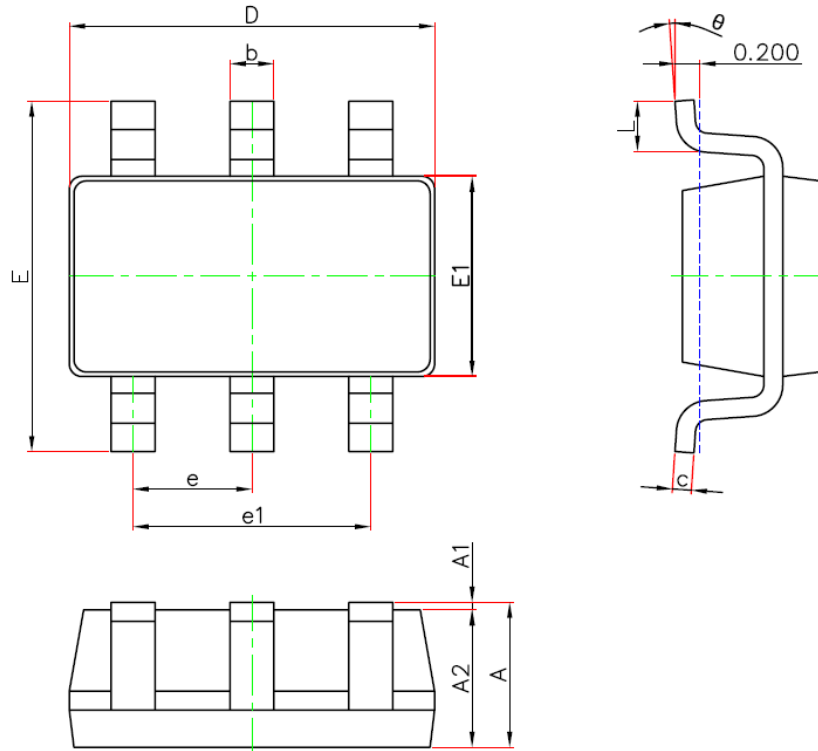

Symbol	Dimensions In Millimeters		Dimensions In Inches	
	Min.	Max.	Min.	Max.
A	1.050	1.250	0.041	0.049
A1	0.000	0.100	0.000	0.004
A2	1.050	1.150	0.041	0.045
b	0.300	0.500	0.012	0.020
c	0.100	0.200	0.004	0.008
D	2.820	3.020	0.111	0.119
E1	1.500	1.700	0.059	0.067
E	2.650	2.950	0.104	0.116
e	0.950(BSC)		0.037(BSC)	
e1	1.800	2.000	0.071	0.079
L	0.300	0.600	0.012	0.024
θ	0°	8°	0°	8°

Consonance Electronics does not assume any responsibility for use of any circuitry described. Consonance Electronics reserves the right to change the circuitry and specifications without notice at any time.